

MRE Disc Brake Caliper - Pneumatically Applied, Spring Released

Nominal dimensions are given
For caliper dimensions see DS2000

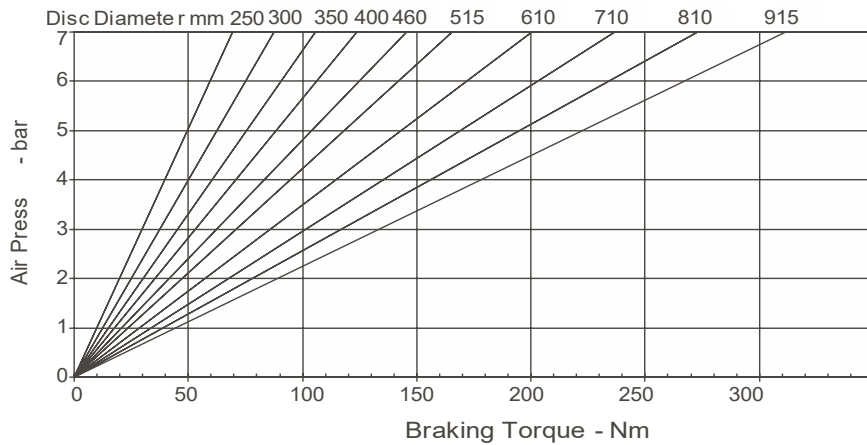
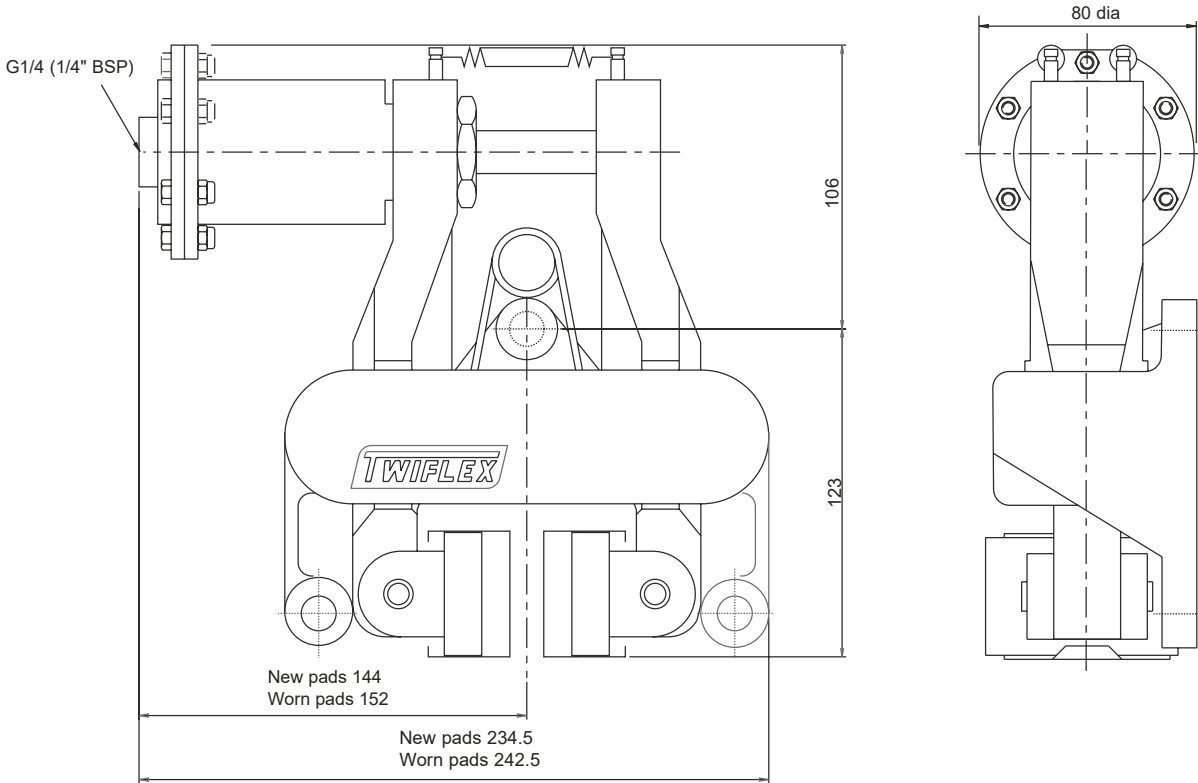

Weight (caliper and thruster) - 6.84kg
(thruster only) - 0.34kg
Volume displacement of thruster at full stroke is 25ml.

Maximum pressure 7 bar
Maximum Braking Force - 0.74kN @7bar

The ratings shown on the above graph are based on fully bedded and conditioned brake pads with nominal friction coefficient $\mu=0.4$.

For bedding-in and conditioning procedures see Publication M1060.

Braking Force is defined as the Tangential Force acting on the brake disc at the Effective Disc Radius.
Braking Torque (Nm) = Braking Force (N) x Effective Disc Radius (m) where Effective Disc Radius = Actual Disc Radius - 0.03.

Twiflex Disc Brakes must be used with Twiflex asbestos free brake pads. The use of any other brake pads will invalidate the warranty. Twiflex Limited reserves the right to modify or change the design without prior notice.

MRE Disc Brake Caliper - Pneumatically Applied, Spring Released

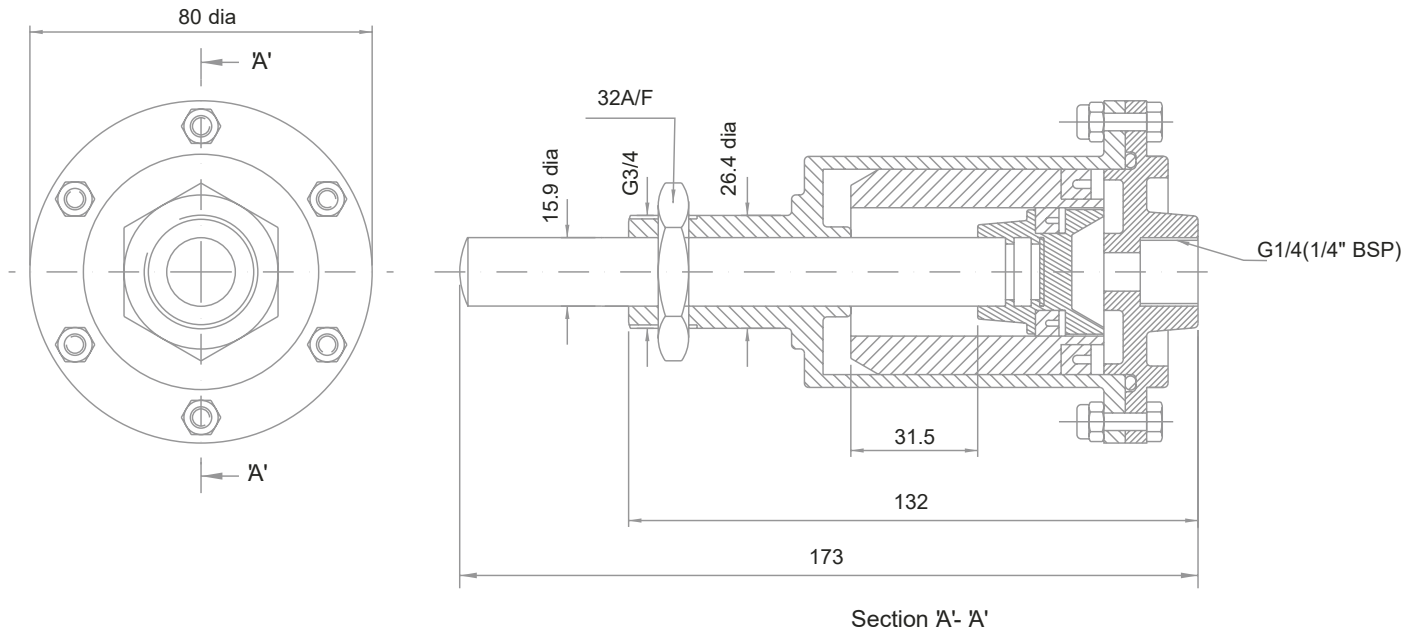

Thruster Part Number 7200478

This range of pneumatically operated brakes uses dry and filtered compressed air at pressures up to 7 bar. Pneumatic brakes require a control valve which may be operated either manually, or by pneumatic or electrical signal.

Thruster Fitment

1. Offer thruster to caliper making sure that both lock nuts are removed before placing push rod through caliper arm.
2. Fit lock nuts over the push rod and locate its end within the slot of the other arm.
3. Tighten one lock nut to 50-60 Nm.

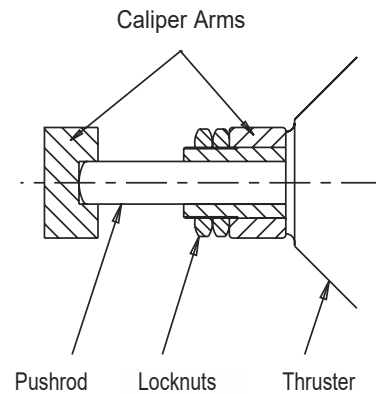

This approval is in Accordance with
Certificate number 850822
Issue 04 June 2009 © Twiflex 2001

Tel: +44 (0)1453 750814
Fax: +44 (0)1453 765320
www.howdon.co.uk
sales@howdon.co.uk