

**'MU' (Mk 2) Series Disc Brake Caliper**

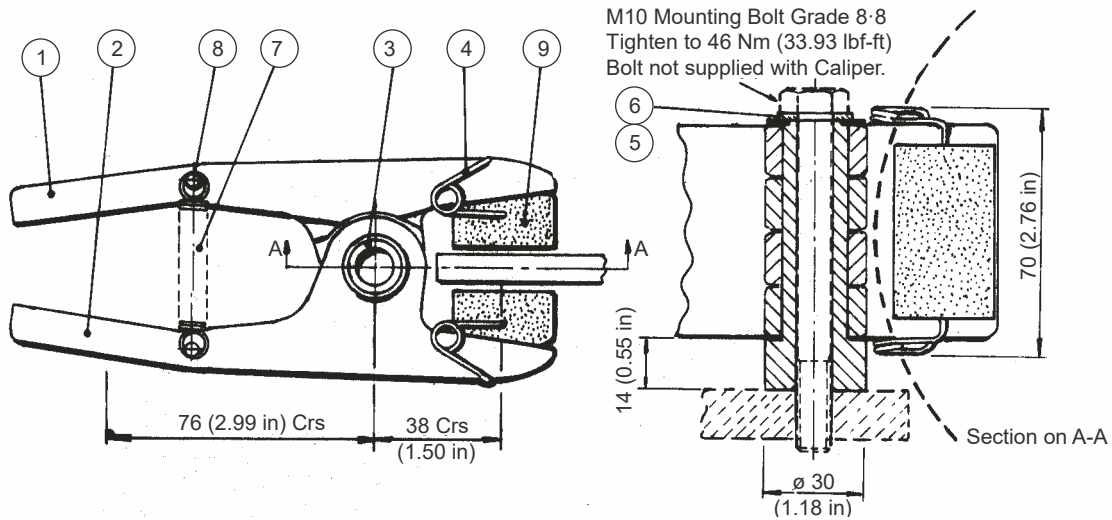

**MU-2 Brake Caliper**

Caliper with Tension Spring Part No. 6780918.

Weight (caliper only)- 0.750 kg (1.65 lb)

**Parts List**

Item	Component	Part No.	Qty.
1	Arm (Thruster Side)	6640177	1
2	Arm (Opposite Side)	6640178	1
3	Pivot Post	8240039	1
4	Pad Retaining Spring	2400093	2
5	9/16" Plain Washer	4700209	1

Item	Component	Part No.	Qty.
6	M10 Plain Washer	4700208	1
7	Tension Spring	2400109	1
8	Grooved Pin	3100088	2
9	Brake Pad	7080047	2

**General Description**

The MU' series of disc brake calipers is the smallest in the Twiflex range and is designed for light duty stopping and holding applications.

The range consists of three spring applied, air released brake calipers type MUS2, MUS3 and MUS4; one handwheel adjustable spring applied, brake caliper type MUH; one air applied, spring released disc brake caliper type MU3 and one direct air applied brake caliper type MUP.

This range of brakes is normally used with 8mm (0.31 in) thick discs having a minimum dia. of 150mm (5.91 in), (these are not available from the standard Twiflex range), but the MUS3 caliper will accommodate discs up to 11 mm

(0.43 in) thick. With a revised thruster mounting arrangement (see page 3) the MUS3 and MU3 calipers can be used

with standard Twiflex discs 12.7mm (0.50 in) thick.

The MUS2 disc brake caliper, the smallest in the spring applied series, has a spring loaded piston type thruster. The MUS3 disc brake caliper, the next in the series, is intended mainly for light holding duties (or for very occasional stopping applications). It has a diaphragm type thruster. No adjustment for brake pad wear is provided.

The MUS4 caliper is similar to the US3 but has a heavier spring. This brake is used for normal stopping and holding duties.

Both the MUS2 and MUS4 calipers have an adjusting screw in the push rod which allows the braking force to be maintained, provided regular adjustments are made to compensate for brake pad wear. The maximum air pressure to be used with these calipers is 7 bar (102 psi).

# Disc Brake Caliper: Type MUS2 - Spring Applied, Air Released

Light duty, stopping and holding.

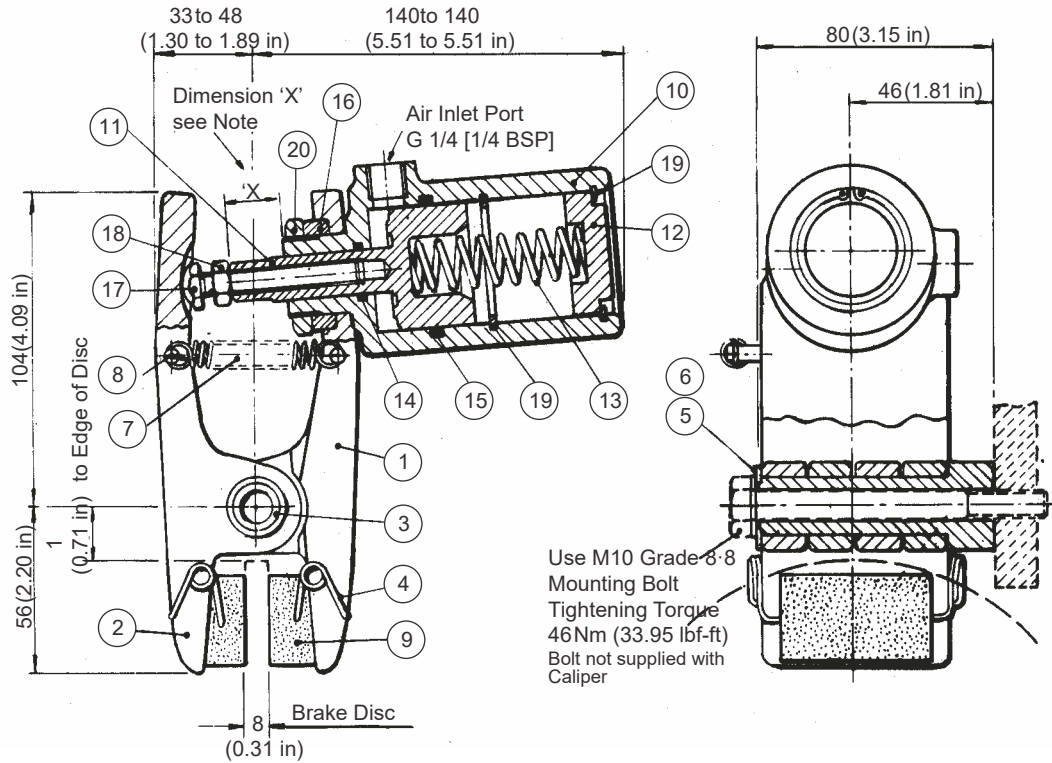

## Disc Brake Caliper Assembly Type MUS2

**Note:** Set dimension X' to 175mm (6.89 in) with brake ON'. This setting corresponds to maximum Braking Force setting. Readjust setscrew (item 17) when dimension X' exceeds 20mm (0.79 in). To avoid damage to thruster diaphragm do not turn the Piston Rod while adjusting the setscrew.

### Parts List

Item	Component	Part No.	Qty.
1	Arm (Thruster Side)	6640177	1
2	Arm (Opposite Side)	6640178	1
3	Pivot Post	8240039	1
4	Pad Retaining Spring	2400093	2
5	9/16" Plain Washer	4700209	1
6	M10 Plain Washer	4700208	1
7	Tension Spring	2400109	2
8	Grooved Pin	3100088	2
9	Brake Pad	7080047	2
10	Cylinder	7241113	1

Item	Component	Part No.	Qty.
11	Piston	7251114	1
12	End Cover	7240932	1
13	Compression Spring	2500186	1
14	O-Ring	6000226	1
15	O-Ring	6000227	1
16	Spacer	1650494	1
17	M8 Adjusting Screw	5300301	1
18	M8 Full Nut	5100188	1
19	Internal Circlip	4300075	2
20	3/4" BSP Nut	5100051	1

### Technical Data MUS2:

Thruster only Part No. 7201112(S2).  
 Caliper only Part No. 6780918.  
 Complete assembly (Caliper and thruster) Part No. 6780922.  
 Weight (complete assembly)- 1.360kg (3.00 lb)  
 Minimum brake disc diameter- 150mm (5.91 in)  
 Disc thickness (Standard) - 8mm (0.31 in)  
 New pad dimensions- 30x50x21mm (1.18 x 1.97 x 0.83 in) thick  
 Brake pad wear allowance - 5mm (0.20 in) each pad  
 Total pad area - 30cm<sup>2</sup> (4.65 in<sup>2</sup>)  
 Minimum pressure for full retraction - 4.3 bar (62 psi).  
 Maximum pressure- 7 bar (102 psi)

**Braking Force** 600 N (135 lbf) at coefficient of friction  $\mu = 0.38$   
 Brake torque (Nm) = Braking force (N) x effective disc radius (m).  
 (Effective disc radius (m) = actual radius (m) - 0.020).

# Disc Brake Caliper: Type MUS3 - Spring Applied, Air Released

Holding Duties and Occasional Stopping

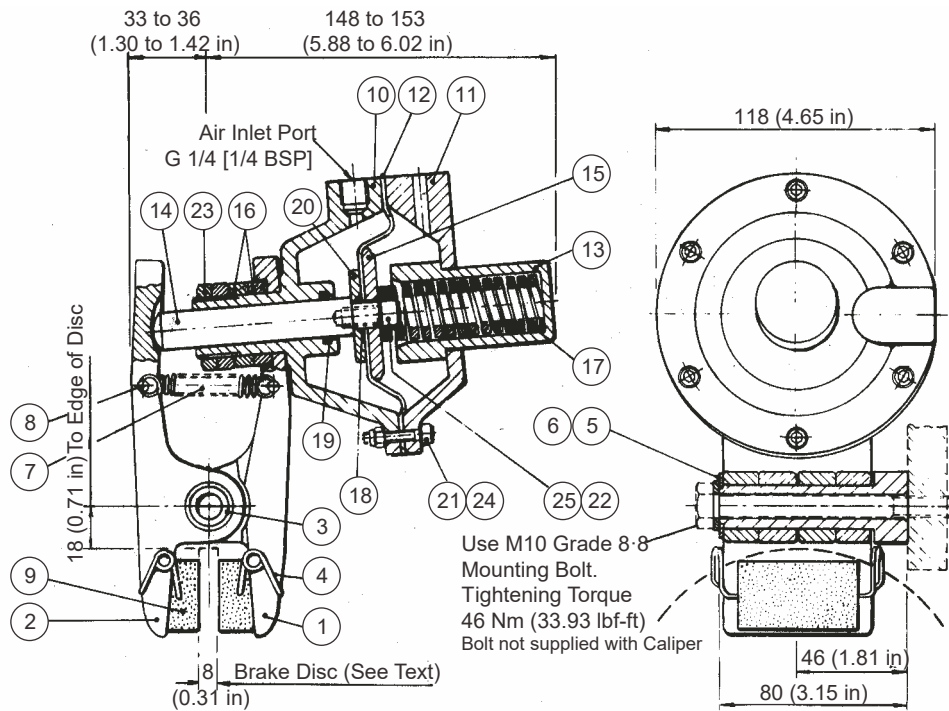

## Disc Brake Caliper Assembly Type MUS

### Parts List

Item	Component	Part No.	Qty.
1	Arm (Thruster Side)	6640177	1
2	Arm (Opposite Side)	6640178	1
3	Pivot Post	8240039	1
4	Pad Retaining Spring	2400093	2
5	9/16" Plain Washer	4700209	1
6	M10 Plain Washer	4700208	1
7	Tension Spring	2400109	2
8	Grooved Pin	3100088	2
9	Brake Pad	7080047	2
10	Front Cap	7240934	1
11	Rear Cap	7240935	1
12	Diaphragm	7200936	1
13	Thruster Spring Cap	7250940	1

Item	Component	Part No.	Qty.
14	Piston Rod	7250946	1
15	Piston Rod Plate	7250938	1
16	Spacer	1650494	2
17	Compression Spring	2500190	1
18	O-Ring	6000304	1
19	Quad Seal	6000299	1
20	Pressure Washer	7200976	1
21	M5x25 Skt Hd Cap Screw	5400331	1
22	M8 Light Washer	4700253	1
23	3/4" BSP Nut	5100051	2
24	M5 Nut	5100195	6
25	M8x26 Skt Hd Cap Screw	5400420	1

### Technical Data MUS3:

Thruster only Part No. 7201126(S3).

Caliper only Part No. 6780918.

Complete assembly (Caliper and thruster) Part No. 6780923.

Weight (complete assembly)- 2.200kg (4.85 lb)

Minimum brake disc diameter- 150mm (5.91 in)

Disc thickness (Standard) - 8mm to 11mm (0.31 to 0.43 in)

New pad dimensions- 30x50x21mm (1.18 x 1.97 x 0.83 in) thick

No pad wear allowance is provided

Total pad area - 30cm<sup>2</sup> (4.65 in<sup>2</sup>)

Minimum pressure for full retraction - 2 bar (29 psi).

Maximum pressure- 7 bar (102 psi)

\*If one of the mounting spacers (Item 16) is repositioned between thruster and caliper, thicker discs up to 13mm can be accommodated. (see scrap view).

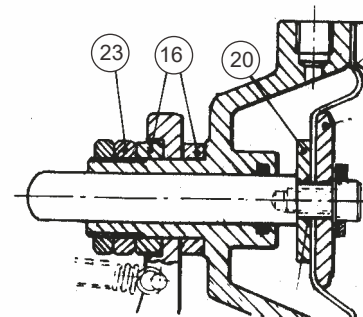

**Braking Force** 780 N (175 lbf) at coefficient of friction  $m = 0.38$   
 Brake torque (Nm) = Braking force (N) x effective disc radius (m).  
 (Effective disc radius (m) = actual radius (m)- 0.020).

# Disc Brake Caliper: Type MUS4 - Spring Applied, Air Released

Stopping and Holding Duties

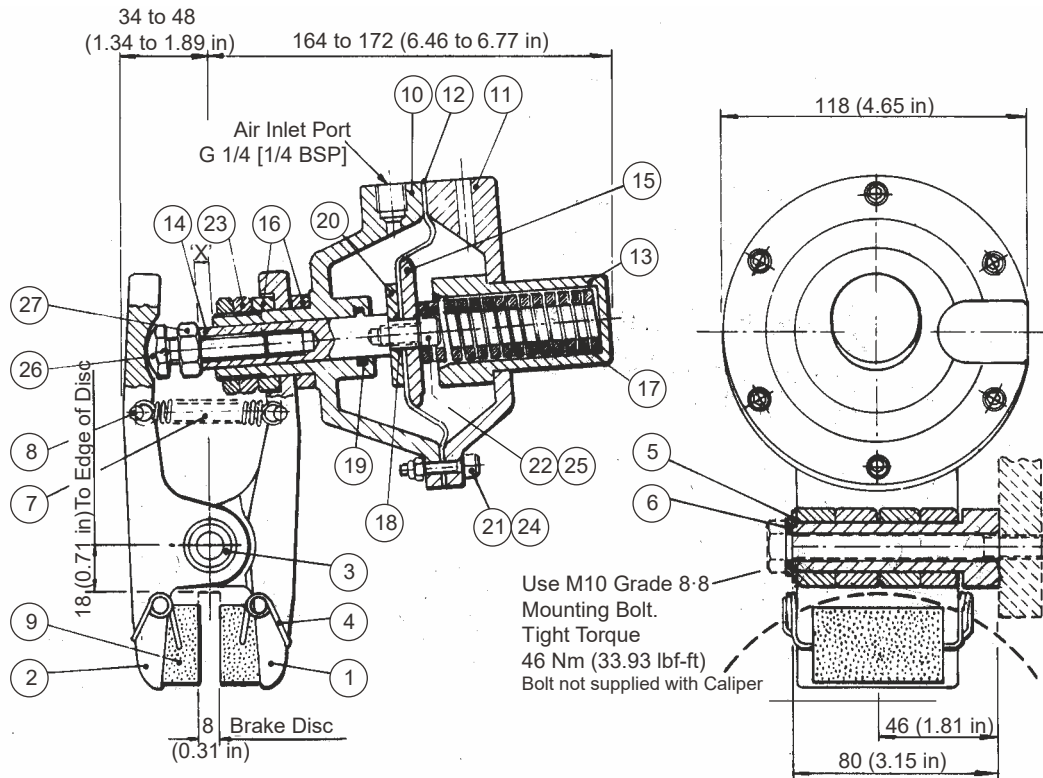

**Disc Brake Caliper Assembly Type MUS4**

**Notes:** Set dimensions "X" to 8mm (0.31 in) with brake ON'. This setting corresponds to maximum Braking Force setting. Readjust set screw (item 26) when dimension 'X' exceeds 10mm (0.39 in). To avoid damage to thruster diaphragm do not turn the piston rod while adjusting the setscrew.

**Parts List**

Item	Component	Part No.	Qty.
1	Arm (Thruster Side)	6640177	1
2	Arm (Opposite Side)	6640178	1
3	Pivot Post	8240039	1
4	Pad Retaining Spring	2400093	2
5	9/16" Plain Washer	4700209	1
6	M10 Plain Washer	4700208	1
7	Tension Spring	2400109	1
8	Grooved Pin	3100088	2
9	Brake Pad	7080047	2
10	Front Cap	7240934	1
11	Rear Cap	7240935	1
12	Diaphragm	7200936	1
13	Thruster Spring Cap	7250940	1
14	Piston Rod	7250937	1

Item	Component	Part No.	Qty.
15	Piston Rod Plate	7250938	1
16	Spacer	1650494	2
17	Compression Spring	2500191	1
18	O-Ring	6000304	1
19	Quad Seal	6000299	1
20	Pressure Washer	7200976	1
21	M5x25 Skt Hd Cap Screw	5400331	6
22	M8 Light Washer	4700253	1
23	3/4" BSP Nut	5100051	2
24	M5 Nut	5100195	6
25	M8x26 Skt Hd Cap Screw	5400420	1
26	M10x40 Hex Hd Screw	5300268	1
27	M10 Full Nut	5100185	1

**Technical Data MUS4:**

Thruster only Part No. 7201127(S4).  
 Caliper only Part No. 6780918.  
 Complete assembly  
 (Caliper and thruster) Part No. 6780924.  
 Weight (complete assembly)- 2.240kg (4.94 lb)  
 Minimum brake disc diameter- 150mm (5.91 in)

Disc thickness (Standard) - 8mm (0.31 in)  
 New pad dimensions- 30x50x21mm (1.18x1.97x0.83 in) thick  
 Brake pad wear allowance - 5mm (0.20 in) each pad  
 Total pad area - 30cm<sup>2</sup> (4.65in<sup>2</sup>)  
 Minimum pressure for full retraction - 6.2 bar (90 psi).  
 Maximum pressure- 7 bar (102 psi)

**Braking Force** 2600 N (584 lbf) at coefficient of friction  $m = 0.38$   
 Brake torque (Nm) = Braking force (N) x effective disc radius (m).  
 (Effective disc radius (m) = actual radius (m)- 0.020).

# Disc Brake Caliper: Type MUH - Hand Operated, Spring Applied

Handwheel Adjustable

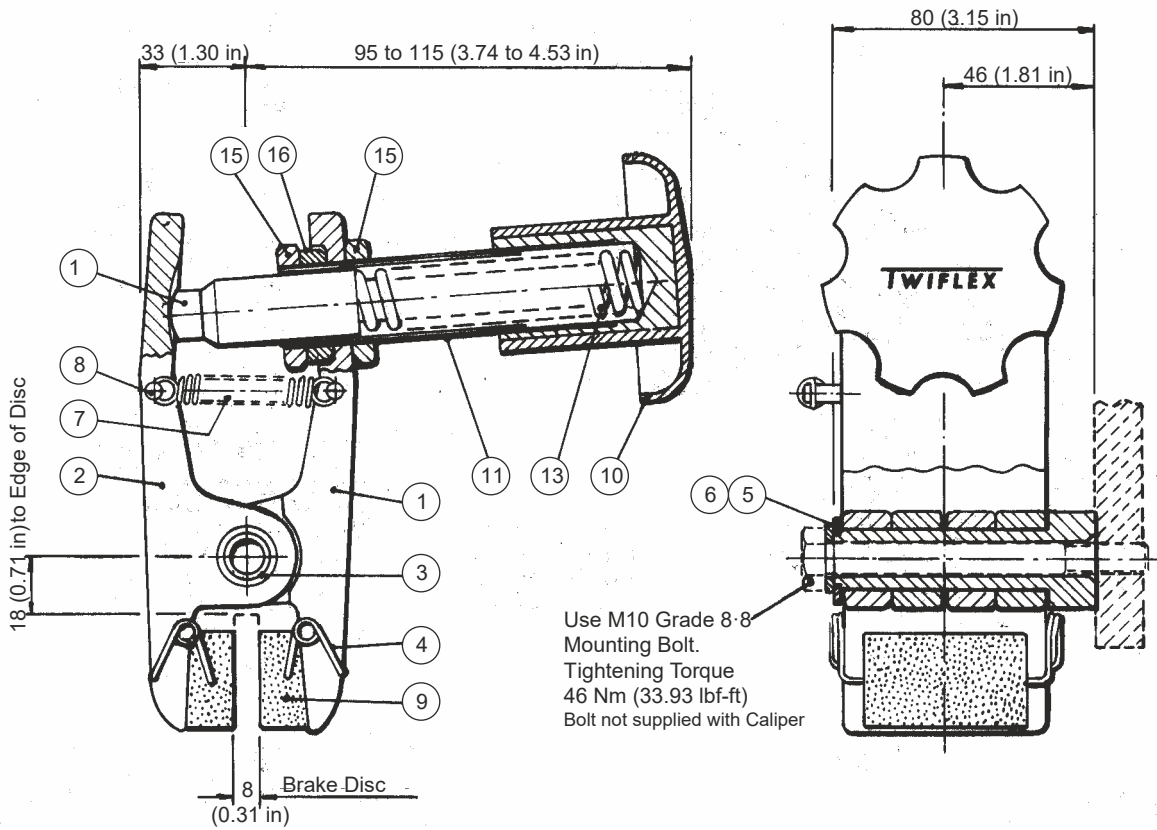

## Disc Brake Caliper Assembly Type MUH

### Parts List

Item	Component	Part No.	Qty.
1	Arm (Thruster Side)	6640177	1
2	Arm (Opposite Side)	6640178	1
3	Pivot Post	8240039	1
4	Pad Retaining Spring	2400093	2
5	9/16" Plain Washer	4700209	1
6	M10 Plain Washer	4700208	1
7	Tension Spring	2400109	2
8	Grooved Pin	3100088	2

Item	Component	Part No.	Qty.
9	Brake Pad	7080047	2
10	Hand Knob	7900637	1
11	Sleeve	7950388	1
12	Push Rod	7952012	1
13	Spring	2500109	1
14			
15	3/4" BSP Nut	5100051	2
16	Spacer	1650494	1

### Technical Data MUH:

Hand Knob Assembly only Part No. 7800173.

Caliper only Part No. 6780918.

Complete assembly (Caliper and hand knob assembly) Part No. 6780925.

Weight (complete assembly) - 1.150kg (2.54 lb)

Minimum brake disc diameter - 150mm (5.91 in)

Disc thickness (Standard) - 8mm (0.31 in)

New pad dimensions - 30x50x21mm (1.18x1.97x0.83 in) thick

Brake pad wear allowance - 2mm (0.08 in) each pad maximum

Total pad area - 30cm<sup>2</sup> (4.65 in<sup>2</sup>)

**Braking Force** 560 N (125 lbf) at coefficient of friction  $\mu = 0.38$   
 Brake torque (Nm) = Braking force (N) x effective disc radius (m).  
 (Effective disc radius (m) = actual radius (m) - 0.020).



# Disc Brake Caliper: Type MU3 - Air Applied, Spring Released

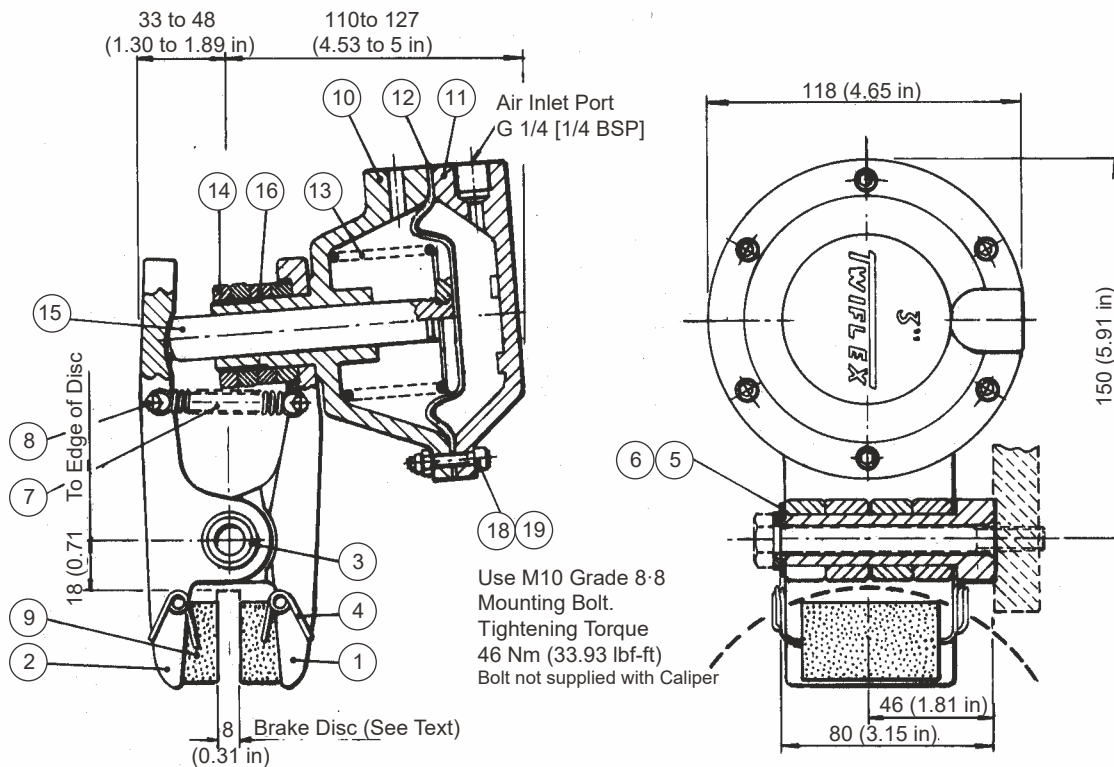

**Disc Brake Caliper Assembly Type MU3**

**Parts List**

Item	Component	Part No.	Qty.
1	Arm (Thruster Side)	6640177	1
2	Arm (Opposite Side)	6640178	1
3	Pivot Post	8240039	1
4	Pad Retaining Spring	2400093	2
5	9/16" Plain Washer	4700209	1
6	M10 Plain Washer	4700208	1
7	Tension Spring	2400109	1
8	Grooved Pin	3100088	2
9	Brake Pad	7080047	2
10	Front Cap	7240799	1

Item	Component	Part No.	Qty.
11	Rear Cap	7240800	1
12	Diaphragm	7200786	1
13	Compression Spring	2550060	1
14	3/4" BSP Nut	5100051	2
15	Piston Rod Assembly	7200919	1
16	Spacer	1650494	2
17			
18	M5x25 Skt Hd Cap Screw	5400331	6
19	M5 Nut	5100195	6
20			

**Technical Data MU3:**

Thruster only Part No. 7201125.

Caliper only Part No: 6780918.

Complete brake assembly Part No. 6780921.

Weight (complete assembly)- 1.900kg (4.19 lb)

Minimum brake disc diameter- 150mm (5.91 in)

Disc thickness (Standard) - 8mm (0.31 in)

New pad dimensions- 30x50x21mm (1.18x1.97x0.83 in) thick

Brake pad wear allowance - 5mm (0.20 in) each pad

Total pad area - 30cm<sup>2</sup> (4.65 in<sup>2</sup>)

Maximum pressure - 5 bar (72 psi)

Volume displacement of thruster at 13mm (0.51 in) stroke- 46 ml (1.56 fl oz)

Max. volume displacement at 30mm (1.18 in) stroke- 105 ml (3.55 fl oz)

The above Braking Torque graph for Type MU3 Brake is for bedded and conditioned brake pads having a coefficient of friction of 0.38 when used with Standard Twiflex brake disc materials.

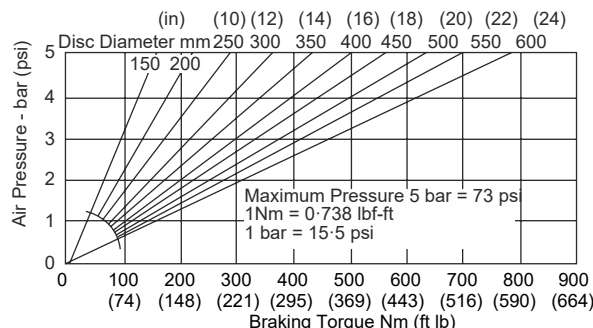

**Braking Force 5 bar (72 psi) = 2750 N (616 lbf)**

Brake torque (Nm) = Braking force (N) x effective disc radius (m).

(Effective disc radius (m) = actual radius (m)- 0.020).

# Disc Brake Caliper: Type MUP - Air Applied

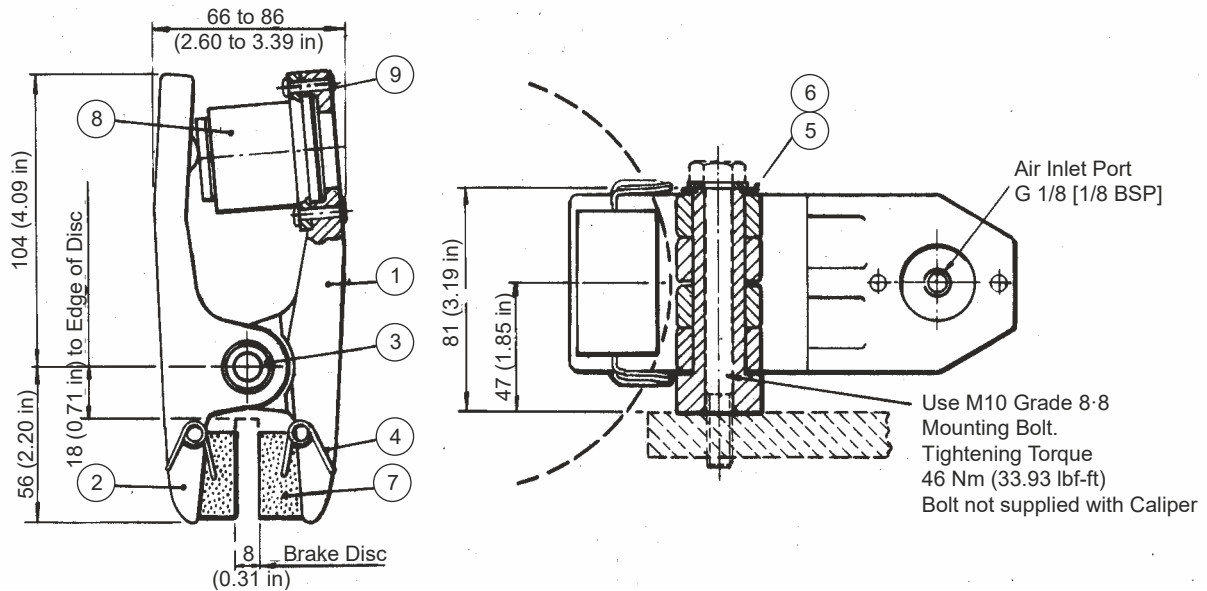

## Disc Brake Caliper Assembly Type MUP

Complete assembly (Caliper and thruster) Part No. 6780919

### Parts List

Item	Component	Part No.	Qty.
1	Arm (Thruster Side)	6640177	1
2	Arm (Opposite Side)	6640178	1
3	Pivot Post	8240039	1
4	Pad Retaining Spring	2400093	2
5	9/16" Plain Washer	4700209	1

Item	Component	Part No.	Qty.
6	M10 Plain Washer	4700208	1
7			
8	Air Thruster	7200525	1
9	5/32"x3/4" Rivet	6540095	2

### Technical Data MUP:

Complete assembly (Caliper and thruster) Part No. 6780919.

Weight (complete assembly) - 0.800kg (1.76 lb)

Minimum brake disc diameter - 150mm (5.91 in)

Disc thickness (Standard) - 8mm (0.31 in)

New pad dimensions - 30x50x21mm (1.18x1.97x0.83in) thick

Brake pad wear allowance - 5mm (0.20 in) each pad

Total pad area - 30cm<sup>2</sup> (4.65in<sup>2</sup>)

Maximum pressure - 7 bar (102 psi)

Volume displacement of thruster at maximum (6mm) (0.24 in) stroke - 3.8 ml (0.13 fl oz)

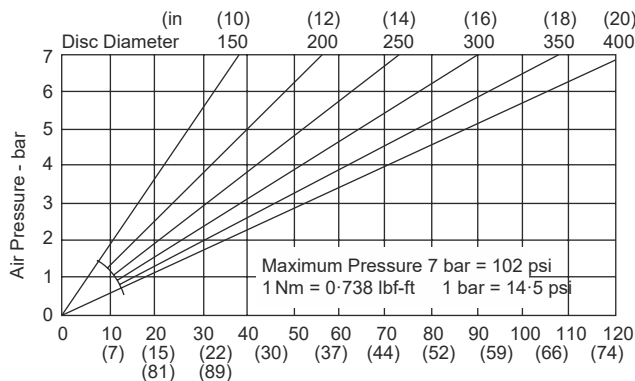

### Brake Performance of MUP Disc Brake Caliper

The ratings shown on the above graph are based on fully bedded-in pads and coefficient of friction of 0.38

**Braking Force** 7 bar (102 psi) = 680 N (153 lbf)

Brake torque (Nm) = Braking force (N) x effective disc radius (m).

(Effective disc radius (m) = actual radius (m) - 0.020).

The MUH disc brake caliper is fitted with a large plastic hand knob for adjustment of the spring thrust and provides an economic and effective brake for light holding duties or as a tensioning brake where hand setting can give an adequate braking control. The thrust force and consequently the braking force can be varied from zero to 560 N at maximum setting at coefficient of friction  $\mu = 0.38$ . The braking force of 560 N holds for pad wear up to 2mm (0.08 in) but declines to 360 N at 5mm (0.20 in) pad wear each pad.

The MU3 is a pneumatically applied, spring released disc brake caliper fitted with a diaphragm type thruster. The braking force available from this caliper decreases slowly from the value in the table (which is for new pads) to 2250 N at 25mm (0.98 in) stroke, equivalent to 3.5mm (0.14 in) wear per pad. Beyond this point the fall off of braking force is more rapid.

The disc brake caliper, type MUP, is the smallest in the Twiflex range. It is a simple air operated direct acting unit without return spring and is supplied fully assembled.

**Performance of Type MU (Mk 2) Disc Brakes:**

Brake Type	Maximum Braking Force	Minimum Pressure for Full Retraction
MUS2	600 N (135 lbf)	4.3 bar (62 psi)
MUS3	780 N (175 lbf)	2 bar (29 psi)
MUS4	2600 N (584 lbf)	6.2 bar (90 psi)
MUH	560 N (125 lbf)	–
MU3	2750 N (616 lbf)	–
MUP	680 N (153 lbf)	–

**Installation:**

Thrusters should be attached to the caliper arm using the spacers and nuts provided, as shown in the drawings on pages 2 to 6. The maximum tightening torque is 60 Nm (44 lbf-ft).

If possible the calipers should be operated using dry, filtered and non-lubricated air.

**Discs:**

The preferred material for the manufacture of discs is spheroidal graphite cast iron. Grey iron can be used, but the maximum speed is reduced by one-third. Forged or wrought (not cast) steel having a hardness of 200HB minimum may also be used. Disc rubbing paths should have a surface finish of 21µm CLA or better, and be flat and parallel within 0.05mm (0.0001 in).

A range of standard discs of 12.7mm (0.50 in) thickness is available from Twiflex (Data Sheet DB5002) which may be used with MUS3 and MU3 brake calipers. Twiflex discs are manufactured to the above limits from spheroidal graphite iron to BS 2789 grade 420/12.

**Selection of Type MU (Mk 2) Disc Brakes:**

Type	Caliper Part No.	Thruster Part No.	Complete Brake Part No.	Characteristics and Applications
MUS2	6780918	7201112	6780922	Spring Applied - air released Light duty, stopping and holding
MUS3	6780918	7201126	6780923	Spring applied - air released Holding duties and occasional stopping
MUS4	6780918	7201127	6780924	Spring applied - air released Light duty, stopping and holding
MUH	6780918	7800173	6780925	Hand operated Holding duties only
MU3	6780918	7201125	6780921	Air applied - spring released Holding and stopping duties
MUP	6780917	7200525 7201111*	6780919	Air applied Light duty, holding duties only



This approval is in Accordance with Certificate number 850822 Issue 04 June 2009 © Twiflex 2001

Tel: +44 (0)1453 750814  
 Fax: +44 (0)1453 765320  
 www.howdon.co.uk  
 sales@howdon.co.uk