

MXEA ELECTRICALLY RELEASED BRAKE

For MX Caliper dimensions see DS2500

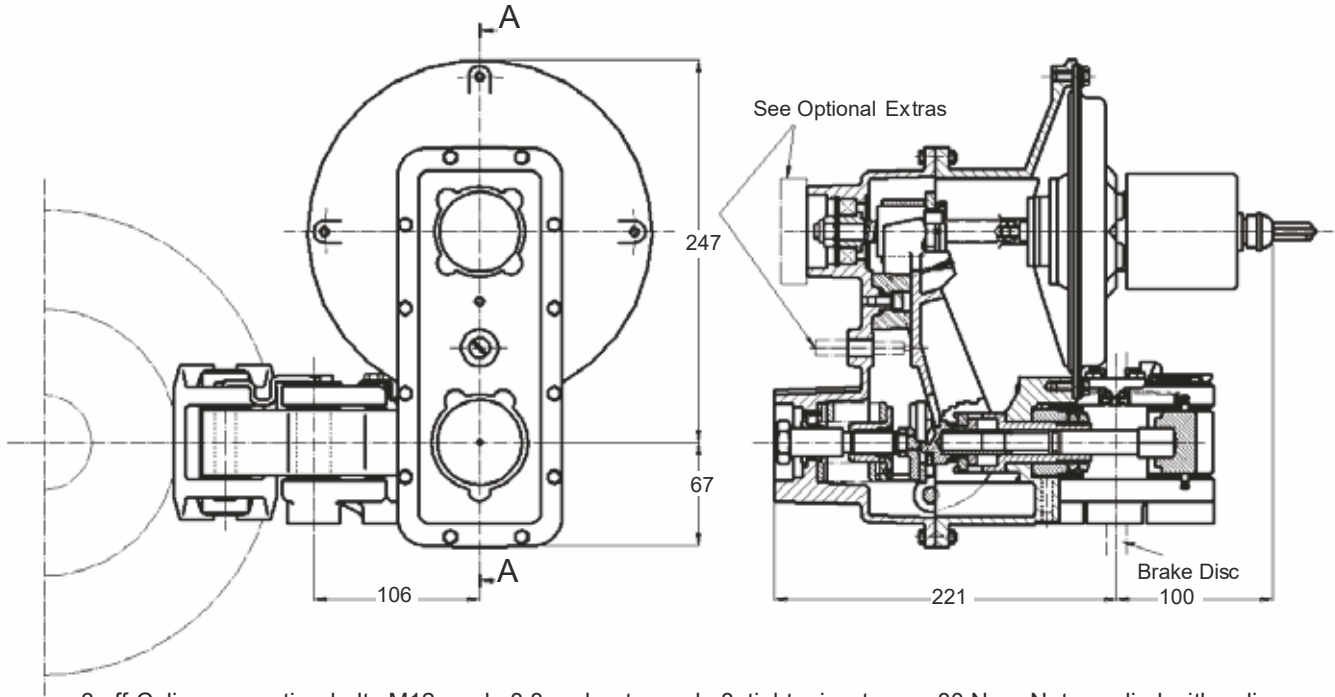

3 off Caliper mounting bolts M12 grade 8.8 and nuts grade 8, tightening torque 80 Nm - Not supplied with caliper

Controller

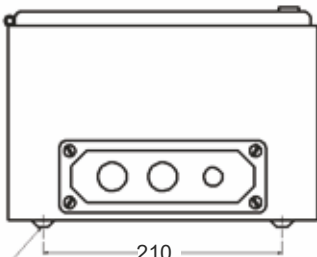
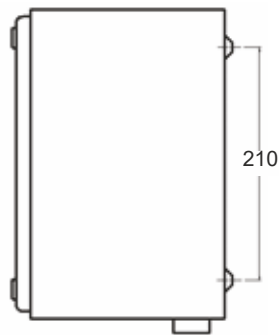

Standard Cabinet
250x250x155 mm
(IP66)

Cable Glands
2 x 20mm
1 x 13mm

4 holes Ø 8.5 (Ø 7)

Caliper constructed from spheroidal graphite cast iron
Actuator constructed from aluminium alloy

- Braking Force:** 6kN (adjustable to 50%)
- Brake Pads:** 104cm² asbestos free. This caliper must be used with Twiflex brake pads. The use of any other brake pad will invalidate the warranty.
- Pad wear allowance:** 7mm (5mm for MX40)
- Weight:** 7.0kg MX Caliper only
8.7kg Actuator only
5.5kg Controller only
- Applications Time:** 0.4sec. max. braking force
- Applications Time:** 0.7sec. min. braking force
- Power Consumption:** 8W Hold
- Electrical Rating:** Continuous
- Operations per Hour:** 720 max continuous

Calipers		Actuator		Controllers			
Type	Part Number	Type	Part Number	Type	Voltage	Peak Input	Part Number
MX	6780685				110/125v 50/60Hz		
MX25	6780710	EA	7701211	AC5	210/250v 50/60Hz	5A at 110v	7701341
MX30	6780711				380/440v 50/60Hz 460/570v 50/60Hz		
MX40	6780712			DC5	24v - 36v DC	25A	7701241

MXEA ELECTRICALLY RELEASED BRAKE

Nominal Disc Size	Disc Thickness	Disc Weight kg	Disc Inertia kgm ²	Braking Torque per Caliper Nm	Maximum Disc Speed rpm	Maximum Number of Calipers per Disc
300	12.7	7.3	0.09	728	6000	2
350	12.7	10.9	0.17	870	5100	2
400	12.7	14.1	0.28	1020	4400	2
460	12.7	19.1	0.48	1200	3900	2
515	12.7	22.7	0.75	1370	3500	2
610	12.7	33	1.57	1660	2900	4
710	12.7	52.3	3.2	1960	2500	4
810	12.7	85.5	3.57	2280	2200	4
915	12.7	111	10.8	2590	1900	4
610	25.4	66	2.15	1660	2900	4
760	25.4	104	7	2120	2300	4
915	25.4	150	16	2590	1900	4
1065	25.4	220	29.1	3050	1600	4
1220	25.4	273	49.1	3520	1400	4
1370	25.4	346	80.1	3980	1200	4
1525	25.4	393	120.5	4450	1100	4

For Twiflex standard discs and mounting bosses see Data sheet DS5002 for detailed dimensions

Braking Torque shown in the above table can be adjusted by the user to any level down to 50% of these values with standard Twiflex bedded and conditioned friction pads.

See Manual M1060 for general guidance on running in and conditioning procedures for brake pads.

Braking force is defined as the tangential Force acting on the brake disc at the Effective Disc Radius.

Braking Torque (Nm) = Braking Force (N) x Effective Disc Radius (m)

Where Effective Disc Radius = Actual Disc Radius – 0.033m.

Optional Extras

1. An inductive proximity switch, such as part number 7700945 (DC) and 7701295 (AC), can be fitted in the position indicated in the drawing. This acts as a brake off indicator.
2. The manual lock off device, part number 7903359, may be fitted in the position shown. This can be left permanently installed, and allows the locked off brake to be rapidly re-applied by a simple manual action.

Installation, Operation and Maintenance of MXEA

1. Installation

- 1.1 Check that disc and brake pads are clean and free from oil or other contamination.
- 1.2 The calipers should be mounted on a rigid horizontal base~ and aligned to the disc. If angled mounting is unavoidable a caliper with equalising link mechanism should be used such as MX Caliper with R.H. equalising link. Part No. 6780848 or MX Caliper with L.H. equalising link, Part No. 6780848/AJ11 (unless one pad rubbing is acceptable).
- 1.3 The actuator may be mounted on the caliper either way up. First screw the push rod fully in, and remove the ¾ BSP (ISO G¾) nuts. Disconnect the caliper return springs from the caliper arms. Fit the actuator mounting barrel through the caliper arm and replace the nuts. Supporting the weight of the actuator tighten the first nut to 60 Nm (44 lb.ft.) maximum torque, then tighten the lock nut. The actuator stroke must be adjusted before use, see 1.7.

MXEA ELECTRICALLY RELEASED BRAKE

- 1.4 The controller cabinet is designed for wall mounting. The Ø 7 fixing holes are accessible when the door is opened. The cabinet may also be mounted with the gland plate to the side, or on its back if necessary
- 1.5 The pancake motor is fitted with an auxiliary brake for holding purposes, and there is a composite cable with brown and blue cores for the motor and white for the auxiliary brake. These must be connected to the terminal rail as shown on the label inside the controller lid. It is preferable to use the cable as supplied, length 2 metres, or it may be shortened if required. If it is necessary to lengthen the cable, shorten it to one metre first then use cable of 2.5 mm² for extensions up to 3m and 4 mm² for extensions up to 6 metres for the motor leads. 1 mm² is adequate for the auxiliary brake leads. It is also necessary to connect a remote control switch to terminals 10 and 11; see paragraph 1.6 below.
Route the cable to allow for small movements as the brake operates.
- 1.6 The AC5 controller accepts power supplies of 110/125v, 210/250v, 380/440v or 460/570v at 50/60 Hz, which are selected by using the appropriate terminal. The power supply is permanently connected; control is via the remote control terminals, which should be connected to a suitable voltage free switch or relay, or the auxiliary contacts of a contactor. Closing the contacts releases the brake. As this input is low impedance, low current (10mA) and optically isolated it is not sensitive to any external electrical interference, and there is no realistic limit to the length of the cable between the remote control terminals and the controller.
The DC5 controller requires a nominal 24-36vdc supply with a peak short-term current capacity of at least 25 amps.

1.7 Adjustment

Energise the controller the push rod will retract by 8-9mm. **Taking care that the fingers cannot be trapped** in the event of power loss, unscrew the push rod as far as possible — i.e. until the corners of the hexagon are just touching the edges of the slot in the opposite arm, with the brake pads in contact with the disc. Align the hexagon and engage the push rod in the slot. Replace the caliper return springs.

This procedure should achieve the correct operating stroke of 4-4.5mm, which will then be maintained automatically by the patented adjusting mechanism.

The actuator must not be repeatedly operated with excessive stroke, or when removed from the caliper, as this will eventually cause damage.

- 1.8 The brake actuator is factory set for maximum braking force. This can be reduced by anticlockwise rotation of the bolt (24mm a/f) under the plastic cap at the base of the unit (inline with the push rod). Approximately $7\frac{3}{4}$ turns total adjustment are provided, after which the bolt will be felt to be free of spring load. This is the minimum adjustment position, giving approximately 50% of the maximum braking force. Thus, the braking force is changed by about 6.5% of the maximum per turn. The adjustment should be carried out with the brake on.
If more than one caliper is used on a disc ensure that the braking force setting is the same for each, to achieve simultaneous operation.
- 1.9 Check brake operation and carry out any required testing. Note that full braking torque will be achieved only after the pads have bedded-in.

2. Operation

- 2.1 The brake is applied in 0.4 seconds when adjusted to maximum spring force; this increases to 0.7 seconds at minimum spring force. Retraction is significantly faster than application, of the order of 50%, and the disc will begin to move instantaneously.
- 2.2 Manual release of the brake is possible by turning the 17mm A/F nut (under the appropriately marked red cover) in a clockwise direction by not more than 4 turns, after taking up the free movement. The optional manual lock-off device allows the locked off actuator to be quickly re-applied manually without the use of any tool.

3. Maintenance

- 3.1 Check the brake and controller as necessary to ensure that they remain clean and dry, and Especially that the brake pads and disc are free of oil or other contaminants.
- 3.2 Carry out any periodic statutory testing that is required, or otherwise check for satisfactory performance.

MXEA ELECTRICALLY RELEASED BRAKE

- 3.3 Replace friction pads when worn. The stroke of the hexagon thrust rod is maintained at approximately 4mm by the automatic adjusting mechanism in the actuator as pad wear occurs, maintaining constant spring thrust. When any one pad is worn down by 7mm (5mm for MX4O) at any point from new, all the brake pads should be replaced.
- 3.4 To replace the pads, secure the installation as necessary to ensure safety while the brake is released electrically or manually (see under Operation). Screw back the hexagon thrust rod to create space between pads and disc. Straighten the retaining tabs and remove the worn pads. Clean the disc and the pad recesses in the shoes and fit new pads. Bend the tabs through 90° to retain pads.
Readjust the actuator stroke to 4 to 4.5mm.
- 3.5 Re-machining of the disc brake paths is not necessary unless they are cracked or badly pitted. Some grooving of the disc is normal and not detrimental to performance. Provided the surface has a polished appearance. Disc wear is generally negligible provided that standard Twiflex brake pads are used. If skimming of the brake paths does become necessary, however, the following tolerances must be observed:
Thickness variation of disc flange: 0.05mm total variation.
Maximum thickness of disc flange: 75% of initial thickness.
Maximum run-out of flange: 0.15mm T.I.R.
Surface finish of braking paths: 2 µm CLA.
- 3.6 Under average operating conditions, no regular servicing is required. However, occasionally (the frequency will depend on environmental conditions) the caliper should be dismantled and cleaned and the bearing surface and pivots greased. A medium grease containing molybdenum disulphide (MOS2) is recommended.
- 3.7 After a long period of service, motor performance may deteriorate due to wear of the brushes or the copper tracks of the armature. A new brake/motor assembly should be fitted; this is a quick and simple procedure.
- 3.8 The EA actuator is fitted with a recirculating ball-screw, the efficient operation of which is essential to the safe and reliable operation of the brake. The ball-screw is fitted with a felt oil reservoir, and lubricated with a long life synthetic oil, and should normally require no attention during the life of the brake.

3.9 Fuses

	AC5	DC5
Input (in terminal 1) ϕ 6.3 x 32 (size 0)	T4A (anti surge)	
Output (on PCB) ϕ 6.3 x 32 (size 0)	T12.5A (anti surge)	T12.5A

4. Spares

- 4.1 A spare set of brake pads (Part No. 7080118) should be kept in a dry and secure place where there is no chance of oil pollution.
- 4.2 Spare fuses should be available.
- 4.3 In remote sites, multi-caliper installations, or where continuity of operation is essential, it is advantageous to stock a spare controller and a spare actuator motor.

5. Service

Address all enquiries regarding this equipment to your Twiflex agent or direct to Twiflex Ltd.

This document is the Intellectual Property of Twiflex. The policy of TWIFLEX is one of continuous improvement, and new and better design features may have been introduced since this literature was printed. Please check full specification and plans held by our representative and selling agent as this leaflet does not form part of any contract nor does it constitute an offer.



This approval is in Accordance with
Certificate number 850822
Issue 04 June 2009 © Twiflex 2001 Issue 05

Tel: +44 (0)1453 750814
Fax: +44 (0)1453 765320
www.howdon.co.uk
sales@howdon.co.uk