

MXS Disc Brake Caliper - Spring Applied, Pneumatically Released

Nominal dimensions given
For caliper dimensions see DS2500

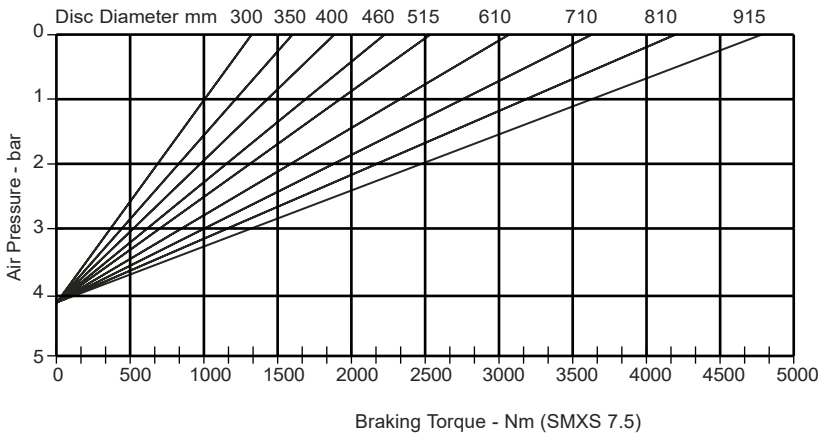
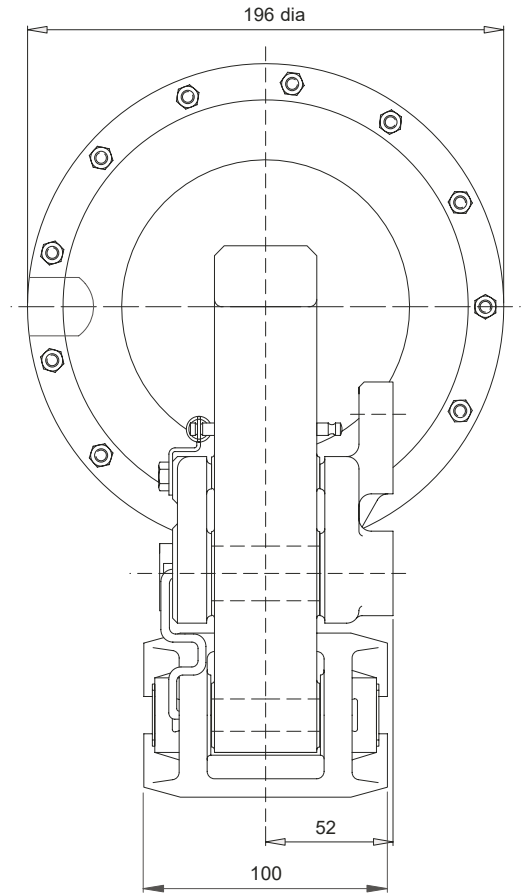
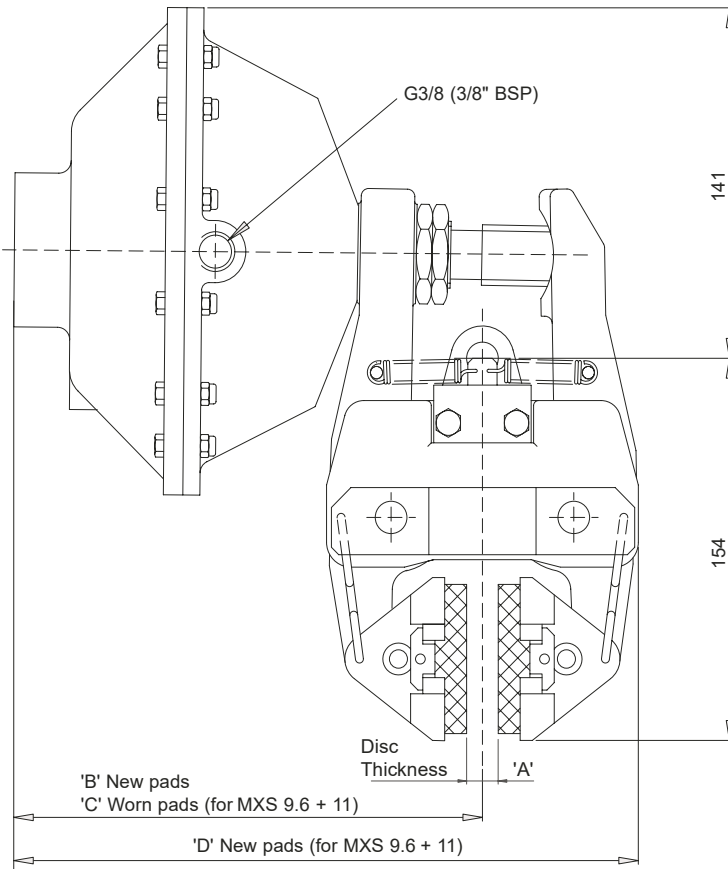

Dimensions in mm				
Caliper	A	B	C	D
MXS 13	13	204.5	212.5	269.5
MXS 25	25	209	217	276
MXS 30	30	204.5	212.5	275.5
MXS 40	40	209	217	284

Weight MXS 9.6 caliper and thruster - 12.1kg
 MXS 7.5 caliper and thruster - 11.9kg
 MXS 4.6 caliper and thruster - 11.5kg
 Caliper only - 7.0kg
 Volume displacement of thruster at full Retraction is 1.19 l

Maximum pressure - 7 bar

Thruster	Maximum Braking Force - Kn	Minimum Pressure for Full Retraction - bar
XS 9.6	14.3	6.4
XS 7.5	11.2	5.5
XS 4.6	6.8	3.1

The ratings shown on the above graph are based on fully bedded and conditioned brake pads with nominal friction coefficient $\mu = 0.4$.

For bedding-in and conditioning procedures see Publication M1060.

Braking Force is defined as the Tangential Force acting on the brake disc at the Effective Disc Radius.
 Braking Torque (Nm) = Braking Force (N) x Effective Disc Radius (m) where Effective Disc Radius = Actual Disc Radius - 0.033.

Twiflex Disc Brakes must be used with Twiflex asbestos free brake pads. The use of any other brake pads will invalidate the warranty. Twiflex Limited reserves the right to modify or change the design without prior notice.

MXS Disc Brake Caliper - Spring Applied, Pneumatically Released

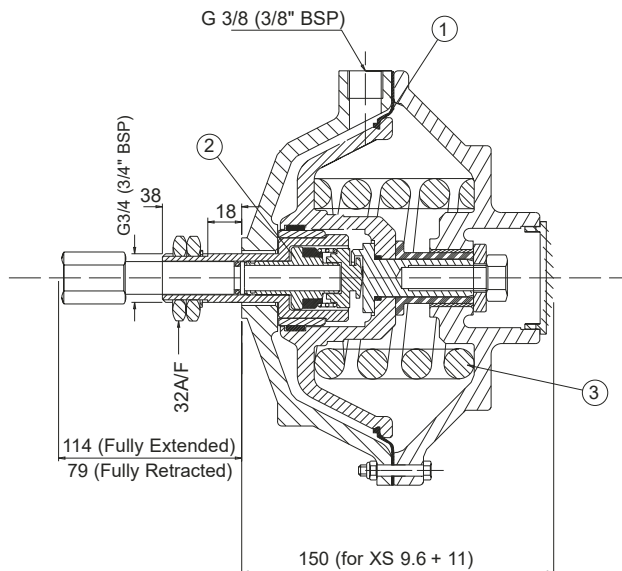
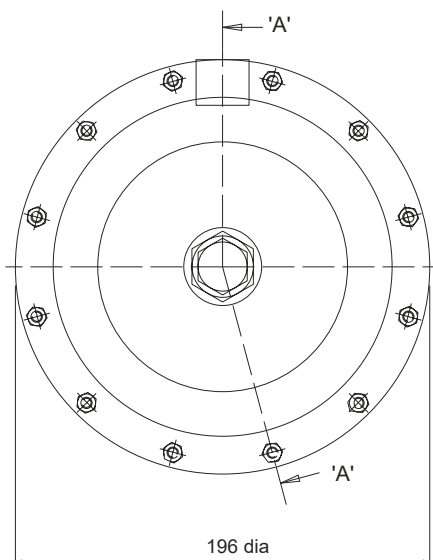

Section 'A' -'A'

AVAILABLE SPARES		
Item	Component	Part No.
1	Diaphragm Kit	7902798
2	Self Adjusting Repair Kit	7902982
3	Spring Kit	7902800

Thruster Part Number:

XS 9.6 7201222

XS 7.5 7201046

XS 4.6 7201076

This range of pneumatically operated brakes uses dry and filtered compressed air at pressures up to 7 bar. Pneumatic brakes require a control valve which may be operated either manually, or by pneumatic or electrical signal.

Should it become necessary to replace a diaphragm, Remove from caliper and ensure air supply is disconnected. Unscrew

and remove push rod. Remove the M5 bolts and the rear cap of the thruster. Remove the worn diaphragm; clean-up the contacting surfaces and re-assemble with the new diaphragm and M5 bolts in position (Tightening Torque 5.7Nm).

Thruster fitment

1. Make sure the thruster rod is extended i.e. it is not pressurised.
2. Take hold of the thruster and turn the push rod via the hex portion clockwise until it stops rotating: so a 'clicking' can be heard from the ratchet. Do this by hand, do not apply heavy force to push the rod once it stops turning.
3. Offer thruster to caliper making sure that both lock nuts are removed before placing hex section of push rod through caliper arm.
4. Pull caliper arms apart so that the pads are hard against the disc.
5. Fit lock nuts to thruster body loosely and unwind push rod until the gap between the body and the arm is 6mm. Make sure that the hex section of the push rod is within the slot of the other arm.
6. Tighten first lock nut to 50 - 60Nm then tighten the second nut against the first.
7. Fit tension spring to arms.

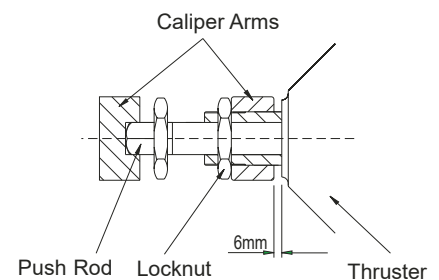

This approval is in Accordance with Certificate number 850822 Issue 04 June 2009 © Twiflex 2001

Tel: +44 (0)1453 750814
 Fax: +44 (0)1453 765320
www.howdon.co.uk
sales@howdon.co.uk