

MXW Disc Brake Caliper - Mechanically Applied, Hand Operated

Nominal dimensions given
For caliper dimensions see DS2500

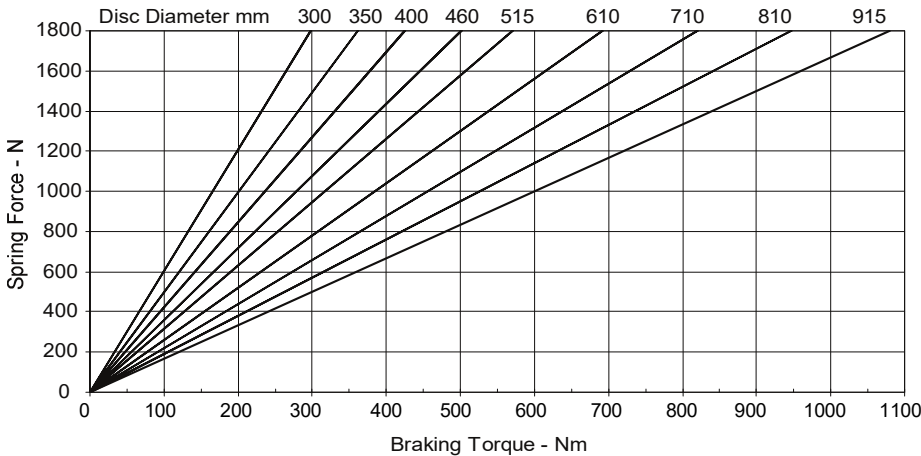
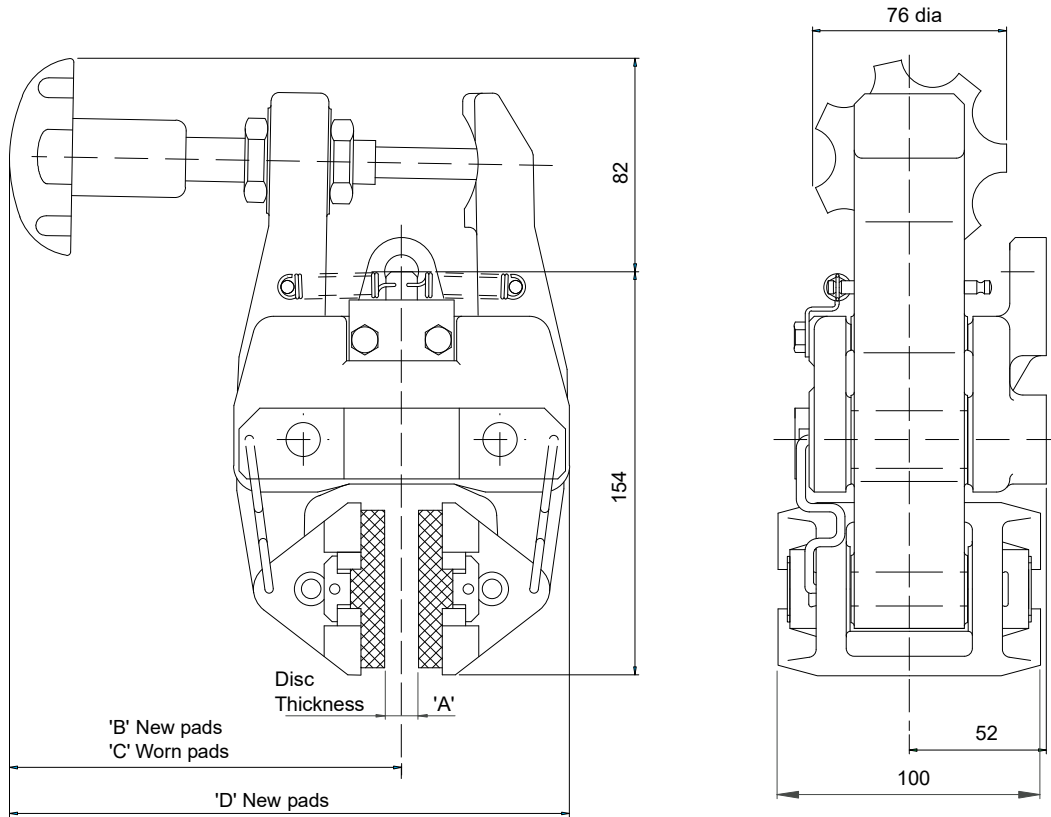

Caliper	Dimensions in mm			
	A	B	C	D
MXW 13	13	150	158	215
MXW 25	25	154	162	221
MXW 30	30	150	158	221
MXW 40	40	154	162	229

Weight Caliper and hand knob - 8.3kg
Hand knob - 1.3kg
1 turn of hand knob = 150N braking force

Maximum Braking Force = 2.68kN

The ratings shown on the above graph are based on fully bedded and conditioned brake pads with nominal friction coefficient $\mu = 0.4$.

For bedding-in and conditioning procedures see Publication M1060.

Braking Force is defined as the Tangential Force acting on the brake disc at the Effective Disc Radius.

Braking Torque (Nm) = Braking Force (N) x Effective Disc Radius (m) where Effective Disc Radius = Actual Disc Radius - 0.033.

Twiflex Disc Brakes must be used with Twiflex asbestos free brake pads. The use of any other brake pads will invalidate the warranty. Twiflex Limited reserves the right to modify or change the design without prior notice.

MXW Disc Brake Caliper - Mechanically Applied - Hand Operated

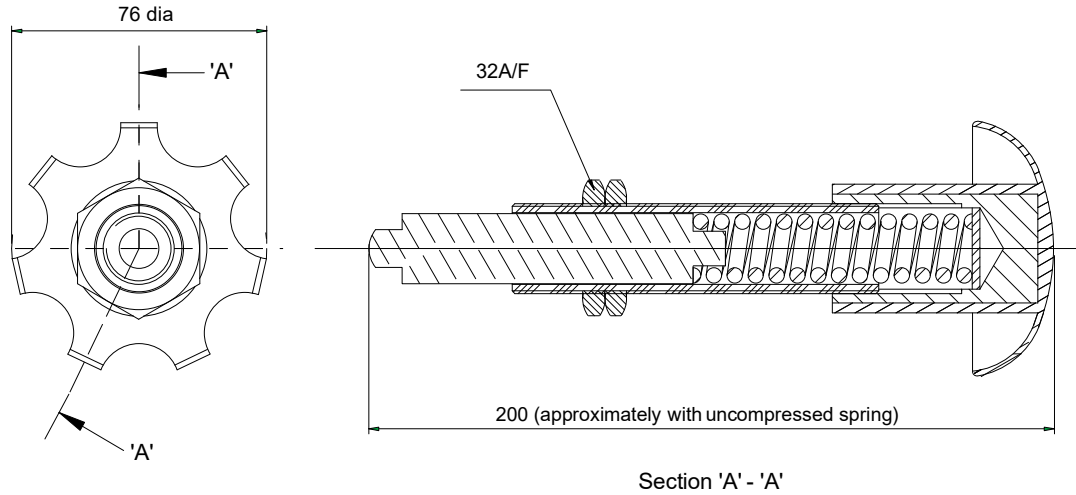

Hand knob assembly 7800126

Thru-rod fitment

1. Offer hand knob assembly to caliper making sure that one lock nut is removed before placing push rod through caliper arm.
2. Fit a lock nut over the push rod, locate the push rod within the slot of the opposite arm.
3. Adjust the lock nuts until the push rod contacts the opposite arm
4. Tighten the lock nuts to 50-60 Nm.

