

Disc Brake Caliper - Type T20 Hydraulically Applied

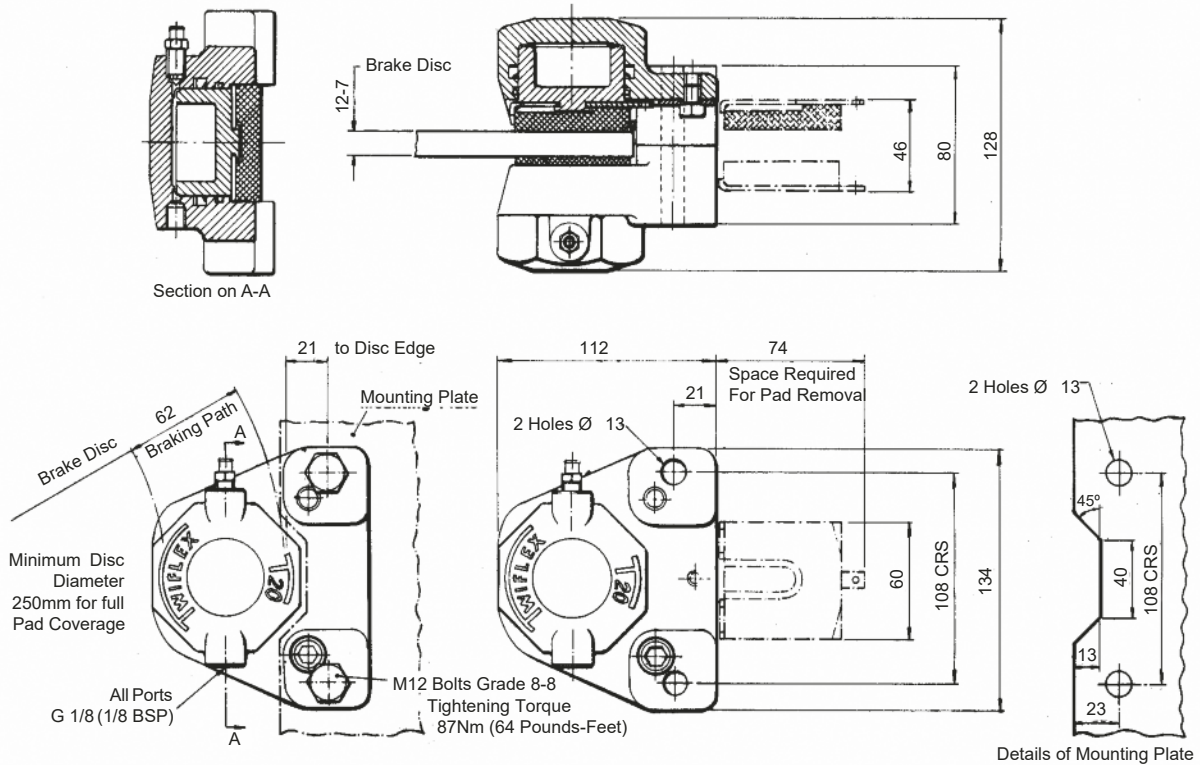

Performance Data

*Braking Force 20kN at 110 bar oil pressure (normal max. working pressure) Braking Torque (kNm) = Braking Force (kN) * x Effective Disc Radius (m) where Effective Disc Radius (m) = Actual Disc Radius (m) - 0.032.

The above Braking Force figure is based on the standard pad friction coefficient $\mu=0.4$.

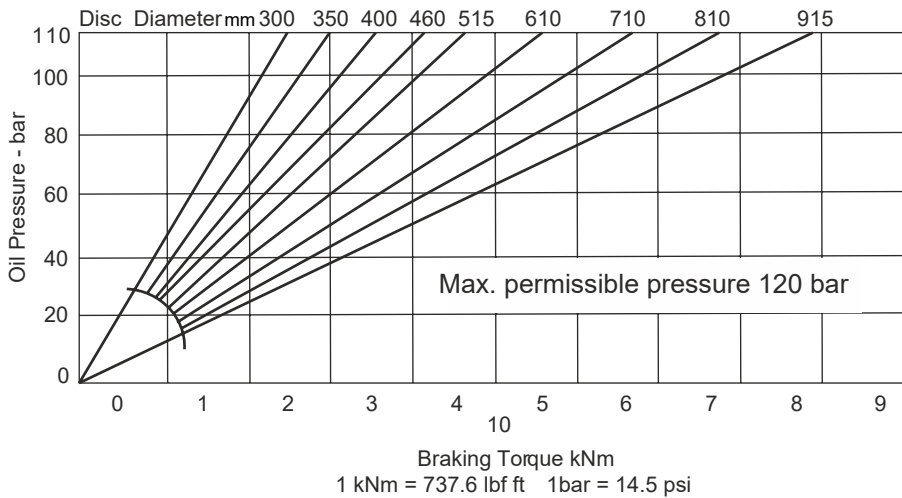

Brake Performance of T20 Disc Brake Caliper

The ratings shown on the above graph are based on fully bedded-in pads.

Disc Brake Caliper - Type T20 Hydraulically Applied

Installation

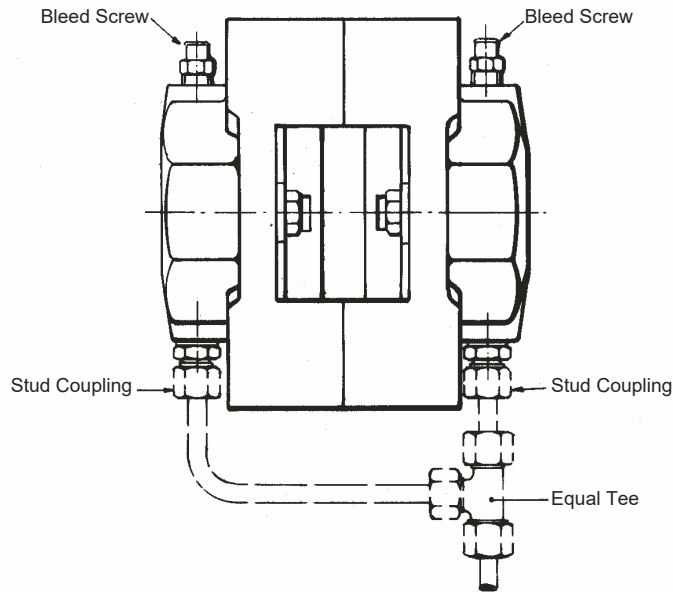

General Description

The standard T20 disc brake caliper is used with 12.7mm thick standard Twiflex discs from 300mm and is cantilever mounted from a side plate. The split design of the T20 caliper also allows its use on thicker discs, in which case a spacer plate is sandwiched between the two caliper halves. The spacer plate may also serve as the mounting plate when the caliper is used with discs of 20mm thickness and upwards. Optionally, the caliper can be supplied in a modified form to suit discs under 12.7mm in thickness. The minimum recommended thickness in this case would be 8mm. It is important that in all cases, the caliper halves are secured together by two cap screws (M12 grade 12.9) tightened to a torque of 130 Nm (97 lbf-ft). In addition two bolts (M12 grade 8.8) should be used for fixing the caliper to the mounting plate. These bolts should be tightened to 87Nm (64 lbf-ft) torque. Bolts can be supplied by Twiflex.

Caliper Packages

| Caliper T20 | Basic Caliper | Pipe Fittings Kit | Combined Part No. Caliper and Pipe Fittings Kit |
|-------------------------|---------------|-------------------|---|
| European Standard | 6781634 | 7300844 | 6781634/AY36 |
| North American Standard | 6781634 | 7300845 | 6781634/AY13 |

Pipe Fittings Kit

Metric Pipe Fittings Kit Part No. 7300844 (to suit steel tubing to DIN 2391/C or BS3602 grade CDS 23, comprising: 2 Male Stud Couplings G1/8 to 6mm and 1 Equal Tee Coupling 6mm.

North American Pipe Fittings Part No. 7300845, comprising: 2 Conversion Adaptors 1/8 BSP to 1/8 NPT.

Spare Parts Kits

Friction Pad Assembly

Part No. 7080134

Piston/Seal Kit

Part No. 6000384 comprising, Two-Part Seal and O-Ring.

Important: This caliper must only be used with Mineral Oil Based Hydraulic Fluid

| Inlet Port | Weight | Total Pad Area | Hydraulic Fluid |
|------------|---------|--------------------|---|
| 1/8 B.S.P. | 5.82 kg | 70 cm ² | Shell Tellus 37, Castrol Hyspin AWS 32 or equivalent mineral based oil. |

Seals are also available for use with vegetable based fluids and high temperature applications.

Service and Spares

Address all enquiries regarding this equipment to your Twiflex agent or direct to Twiflex Limited.



This approval is in Accordance with Certificate number 850822 Issue 04 June 2009 © Twiflex 2001

Tel: +44 (0)1453 750814
 Fax: +44 (0)1453 765320
www.howdon.co.uk
sales@howdon.co.uk