

**CE/2 Disc Brake Caliper - Hydraulically Applied**

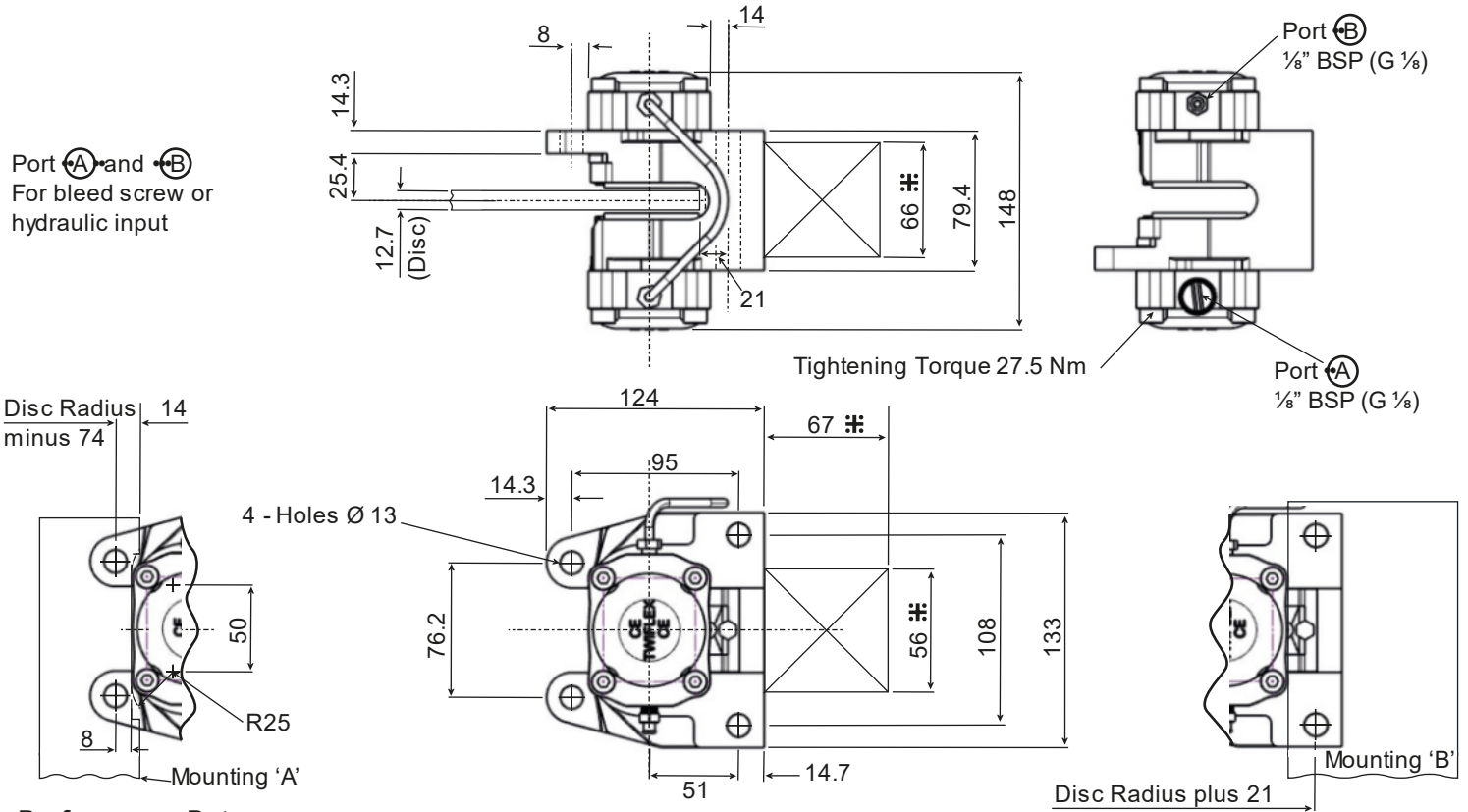

**Performance Data:**

\*Braking Force; 19.6kN at 120 bar oil pressure (normal maximum working pressure).

Braking Torque (kNm) = Braking Force (kN) \* Effective Disc Radius (m).

Where Effective Disc Radius (m) = Actual Disc Radius (m) - 0.030.

The above Braking Force figure is based on the standard pad friction coefficient  $\mu = 0.4$ .

**Note.** Dimensions marked **#** show the space required for the removal of pad assemblies.

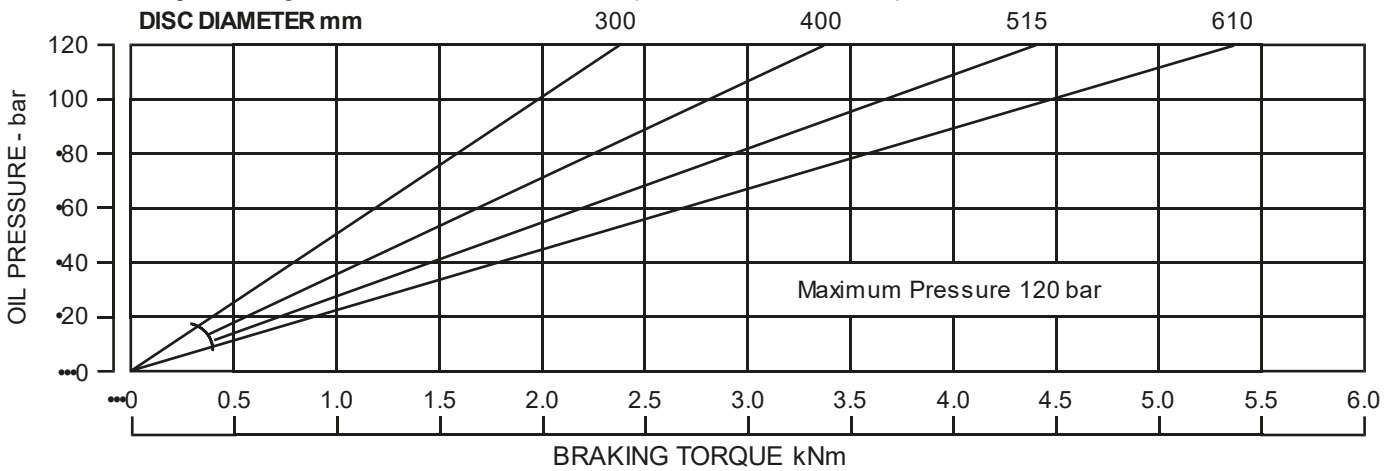

1 kNm = 737.6 lbf-ft

1 bar = 14.5 psi

The ratings shown on the above graph are based on fully bedded-in pads.

**IMPORTANT.** This Caliper must only be used with MINERAL OIL BASED HYDRAULIC FLUID.



This approval is in accordance with  
Certificate number 850822  
Issue 04 June 2009 © Twiflex 2001 Issue 07

Tel: +44 (0)1453 750814  
Fax: +44 (0)1453 765320  
www.howdon.co.uk  
sales@howdon.co.uk

# CE/2 Disc Brake Caliper - Hydraulically Applied

Complete Hydraulic Brake Caliper Assembly for use with Mineral Oil, Part: 6780583.  
 Complete Hydraulic Brake Caliper Assembly for use with Vegetable Oil, Part: 6780632.

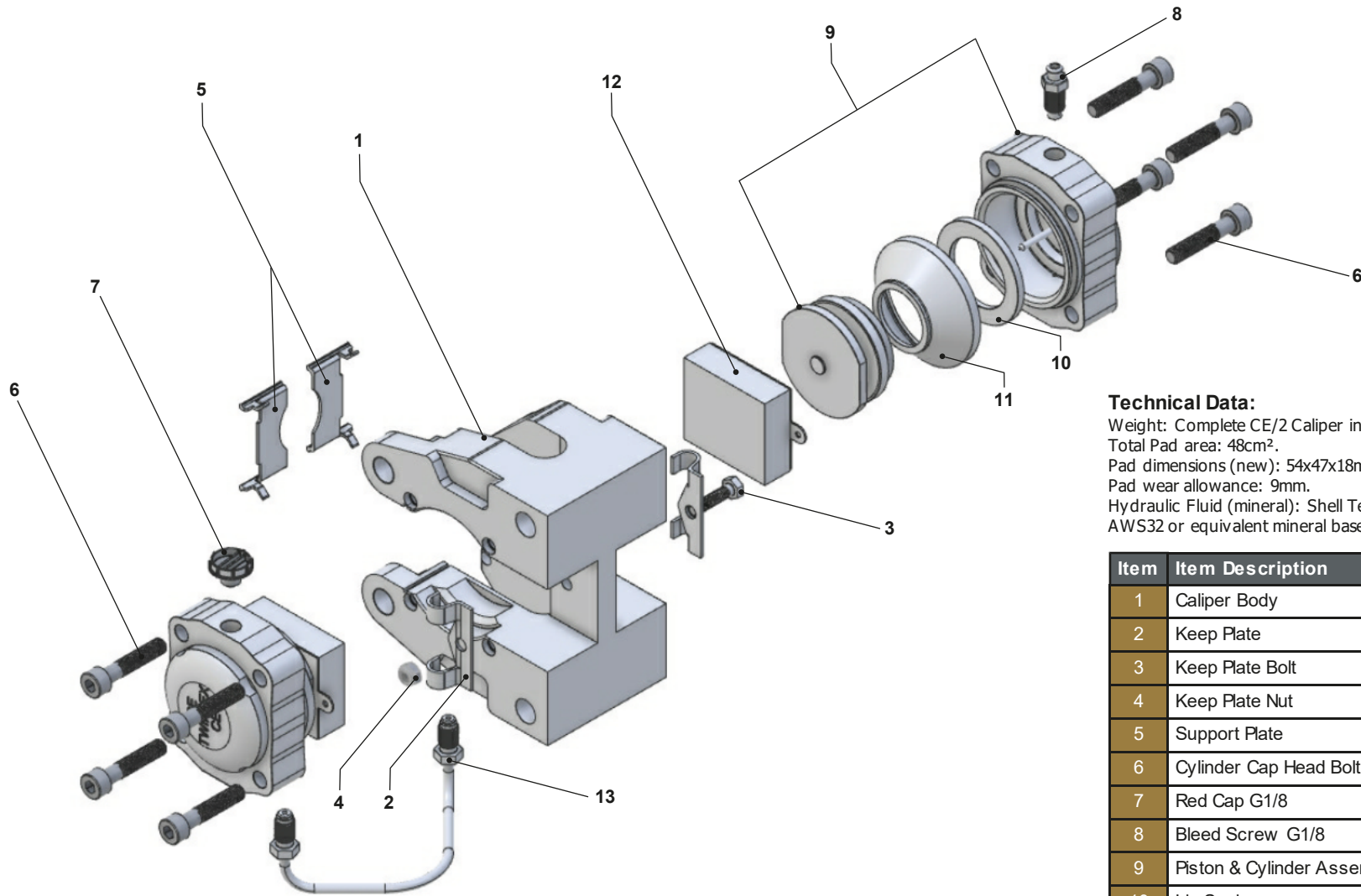

### Technical Data:

Weight: Complete CE/2 Caliper including brake pads: 6.5 kg Approx  
 Total Pad area: 48cm<sup>2</sup>.  
 Pad dimensions (new): 54x47x18mm thick.  
 Pad wear allowance: 9mm.  
 Hydraulic Fluid (mineral): Shell Tellus 37, Castrol Hyspin  
 AWS32 or equivalent mineral based oil.

Item	Item Description	Quantity	Part Number
1	Caliper Body	1	6600132
2	Keep Plate	2	6700178
3	Keep Plate Bolt	1	5000111
4	Keep Plate Nut	1	5100031
5	Support Plate	2	6700242
6	Cylinder Cap Head Bolt	8	5400293
7	Red Cap G1/8	1	8300041
8	Bleed Screw G1/8	1	6700217
9	Piston & Cylinder Assembly	2	6700584
10	Lip Seal	2	6000263
11	Dust Seal	2	6700060
12	Liner Assembly	2	0780124-Z
13	Bridge Pipe Assembly	1	7300654

\*Above parts list is for Mineral Oil Caliper only.

### OIL DISPLACEMENT:

Total oil displacement per operation,  
 (I.e. with automatic retraction of 0.25mm at each pad) = 1.2 ml.

Tel: +44 (0)1453 750814  
 Fax: +44 (0)1453 765320  
[www.howdon.co.uk](http://www.howdon.co.uk)  
[sales@howdon.co.uk](mailto:sales@howdon.co.uk)



This approval is in Accordance with  
 Certificate number 850822  
 Issue 04 June 2009 © Twiflex 2001 Issue 07